

THE RECYCLING CHALLENGE IN NORWEGIAN ROAD CONSTRUCTION

Gordana Petkovic
Norwegian Public Roads Administration, Norway

This paper aims at summarizing the goals, the scope and achievements of a 4-year R&D program conducted by the Norwegian Public Roads Administration 2002 – 2005.

INTRODUCTION

The Norwegian Roads Recycling R&D Program (in Norwegian “Gjenbruksprosjektet”) was motivated by national environmental aims of minimizing waste volume and improving waste management. The main objective of the program was to facilitate more frequent and environmentally safe applications of recycled materials in road construction. The program aimed at increasing the general level of knowledge about recycled materials and revising design rules and building processes.

The program presented a significant effort within the Norwegian Public Roads Administration (NPRA), both concerning investment and working hours. It was carried out through participation from all parts of the NPRA and through cooperation with producers of waste based materials, consultants, contractors, other public agencies etc.

All reports (in Norwegian) are available on the R&D program’s web site [1]. The results have also been published in a number of conference papers (in English), which can also be downloaded from the same web site.

BACKGROUND

Norway has an abundance of high quality rock materials. The yearly production of gravel and crushed rock is approximately 50 mill tons, or 11,6 tons /inhabitant. The quality of the available rock material has yielded demanding technical specification concerning aggregates used for construction purposes. These specifications may appear as restrictive in cases when they apply to recycled materials.

Norway does not lack space for landfills. The total surface area of Norway, 324,000 sq km, is inhabited by only 4,3 mill people. Only 15% of the population uses ground water as drinking water and run-off from waste deposits has traditionally not been a problem.

Thus, in terms of available space, natural resources and quality of ground water, land filling still presents an acceptable solution for construction and demolition waste in Norway. This is the

main difference between Norway and other European countries that are often considered as good examples because of the achieved high recycling levels, e.g. the Netherlands and Denmark.

However, an ambitious environmental policy supports recycling and minimizing the volume of waste. In 2000, the Norwegian Parliament (Storting) formulated the aim of achieving 75 % recycling of annually generated waste by 2010 [2,3], raising the aim in 2006 up to 80 % by the year 2012 [4]. The Norwegian building and construction published its own action plan in 2001, with the aim of improving the management of construction and demolition waste [5]. The plan identifies recycling, increased use of prefabrication and module-based production as important methods for reducing the waste volume. The plan also emphasizes the role of the Norwegian Public Roads Administration in including recycled concrete aggregate in design codes. A revised edition of the action plan was published in May 2007 [6], the focus set on dangerous substances, knowledge dissemination and industrial recycling.

In addition, growing public awareness concerning waste minimization and use of natural resources resulted in explicit demands from all sides of the society to contribute to the national environmental aims. Based on experiences in neighboring countries where road authorities consume a large part of construction and demolition waste, the same contribution level was expected from the Public Roads Administration in Norway.

SCOPE OF THE R&D PROGRAM

The first job was to select materials which could be recycled and used in road construction. The general conditions for what can be defined as recycled material are given by the Norwegian Pollution Control Authority (SFT) [7]:

- the material properties need to have a function, apart from filling volume,
- the material has to satisfy previously set specifications, and
- the material has to have a value on the market
- the material has to be clean.

To satisfy these conditions, and in addition taking into consideration the waste volumes generated in Norway and in the requirements in road construction, four main materials were chosen: recycled concrete aggregate (RCA), reclaimed asphalt, and two types of light fill materials: foamed glass and shredded tires.

Industrial waste consisting of coal combustion residues, steel and iron slag has limited volumes in Norway. Municipal solid waste incinerator ash is not included in the program due to the potential labeling as hazardous waste in Norway. However, some testing was performed on fly-ash from the paper industry and some previous tests using slag were also looked into.

Potential use for each of these materials in road construction is evaluated on the basis of their technical and environmental properties, both through laboratory and field testing. The chances for successful applications of recycled materials are higher if one focuses on the materials' *advantages* compared to traditional materials.

Each of the materials was treated in the way found suitable concerning the previously mentioned conditions. Table 1 gives an overview of the work carried out for each material. This paper will focus on recycled concrete aggregate.

Table 1. Overview of work performed on each recycled material

	Recycled concrete aggregate	Reclaimed asphalt	Shredded tires	Foamed glass
Volume of annually generated waste (used as basis for the material) in Norway	1,24 mill t construction & demolition waste; 600 000 t concrete and masonry [8]	400 000 t in 2005 [9]	4 million vehicle tires, approx. 32 000 tons. Land filling prohibited in EU 2006 [10]	161000 t glass waste [8]. Approx. 10000 t is estimated to go to producers of glass based building materials.
Motivations for including the material in the program	Large volume of generated waste, good experience from earlier applications	Large volumes, valuable waste material, well known technology for recycling	Need for light weight filling materials, examples of successful reuse of tires (USA)	Need for light weight filling materials and insulation materials, new glass products available
Documentation of material properties	* laboratory testing – as road construction material, and concrete aggregate. Focus on durability related properties. * field tests: road sub-base, structural concrete (including 100% replacement of coarse aggregate)	KFA – national system for control and documentation of reclaimed asphalt, active since 2001, was used as framework for work within the NPRA-program [11,12,13,14] Field applications: warm and cold recycling in surface layers, also unbound application in road-base [15,16].	Laboratory tests: literature survey Field tests: full scale noise barrier (10000 t of tire shreds) with sealed bottom and instrumentation for environmental measurements [10]	Laboratory tests: literature survey, production control, supplementary tests Field tests: applications and light weight filling materials and insulation materials – monitored with measurements of deformation, temperature and density.
environmental properties	* extensive leaching tests * modeling * field test in specially constructed full scale testing sites instrumented for measuring environmental properties. * formulating limiting values for the content of pollutants.	* laboratory and field test from literature survey used as a basis for formulating limiting values for the content of pollutants [17].	* laboratory tests from literature survey * field tests from monitoring full scale noise barrier * formulating limiting values for the content of pollutants [18].	* production control, supply from literature * extensive leaching and composition measurements * field test in specially constructed full scale testing sites instrumented for measuring envir. properties. * formulating limiting values for the content of pollutants.
from waste to <i>product</i>	* Norwegian quality certification scheme for RCA, four quality classes (bound and unbound based on composition) * pollution requirement from envir. testing	All asphalt not containing PAH (simple check methods established) is approved for recycling.	No quality certification system established, but effort put into developing a CEN document based on a CEN workshop agreement [19]	Preferred ETA (European Technical Approval); achieved for only one product on the market.
Results – situation after the NPRA program	Good experience from lab and field, extensive documentation, good systems for quality control and documentation. However, materials find other paths to reuse mostly in low-quality applications.	Logistics and economy are the main factors for otherwise problem free recycling. Effort put into including clear requirement for recycling in asphalt contracts.	Norwegian Environmental Agency stopped further investigation of possibilities for technical reuse of shredded tires focusing on leaching of phenols and possible reduction of EU-acceptance criteria.	Several active producers on the market. Variable level of documentation of properties.

The program also dealt with handling of waste and the administrative work necessary for recycling, such as legislation, taxes, and relations regarding responsibility. A separate work package was dedicated to studying the environmental impact of recycled materials in road structures.

RECYCLED CONCRETE AGGREGATE (RCA) IN THE R&D PROGRAM

Recycled concrete aggregate (RCA) is produced from concrete and masonry rubble, which constitutes the largest segment of the construction and demolition (C&D) waste in Norway, approximately 600 000 t of the total amount of 1,2 mill t annually generated C&D waste. The estimated recycling percentage of C&D waste in Norway (10-20 %) represents approximately 0.25 % of the annual production of gravel and crushed rock. This indicates that the utilization of available recycled C&D waste does not significantly affect the consumption of natural aggregate.

Nevertheless, several research projects concerning application of RCA were carried out since the mid 90's, with participation from NPRA. The most extensive of them was RESIBA (1999-2002) [20]. Apart from providing good documentation of technical and environmental properties of RCA [21,22,23,24], and experience from demonstration projects [25,26], RESIBA and other early projects gave the first generation framework of regulations and design guidelines:

- Design rules for concrete structures containing more than 20 % RCA [27]
- Guidelines for use of recycled concrete aggregate [28];
- Quality certification system for recycled concrete aggregate [29]. The scheme was taken over and administered by "Kontrollrådet", an organization for certification and approval of building products [30]

The experiences from the early projects formed the basis for including recycled concrete aggregate for the first time in the new edition of the Norwegian specifications for road construction as a material for road sub-base, base and trenches [31]. Based on the work performed before the initiation of the NPRA-program, the decision was to focus on (1) properties that were detrimental for the material's performance in road structures, and (2) durability related properties relevant for outdoor use.

Unbound applications – road sub-base

Material properties and documentation

Systematic testing of recycled concrete aggregate, mostly from the area around Oslo, was performed and reported in reference document [32]. The aims of the investigation were both to test the applicability of the quality certification scheme [30] and to obtain information about the mean values and variation in properties of available RCA. The conclusion of this work was that, in spite of the higher variation on results than usual for traditional aggregate, the properties of RCA show that the material is a very good substitute for traditional rock aggregate, for many applications. Table 2 gives an overview of the properties of the Norwegian recycled concrete aggregate.

Table 2. Properties of RCA in the Oslo area [32]

Parameter	Test method	Type 1	Type 2
Particle density (SSD)	EN 1097-6	2,3-2,6 kg/dm ³	2,3-2,6 kg/dm ³
Water absorption	EN 1097-6	2,7-8,2 %	2,7-14,7 %
Mechanical properties (Los Angeles)	EN 1097-2	23,0-34,3	23,8-41
Shape – Flakiness index (of mat. > 8 mm)	EN 933-3	10-15 10-13	10-15
Organic materials	EN 1744-1	4,1 % (Only one value available)	2,4-11,4
Chloride content	EN 1744-1	0,003-0,007 weight % (water soluble) 0,007-0,013 (acid soluble)	0,003-0,013 (water soluble)
Sulphur-containing compounds	EN 1744-1	0,0095-0,045 weight % (water soluble) 0,42-0,909 (acid soluble)	0,041-0,246 (water soluble)

Mechanical properties of recycled concrete aggregate

Mechanical properties are crucial for performance in road structures. Test methods and adapted quality requirements are still lacking, and good RCA-materials can be rejected due to their poor performance in the Los Angeles test [33]. However, full scale applications have shown that RCA of lower mechanical quality as tested in the laboratory (Los Angeles method) exhibits an equally good or even better performance than rock materials, due to an increase in stiffness with time [34,35].

In the NPRA program, recycled concrete aggregate was tested in tri-axial cells in order to investigate layer properties rather than particle properties [36,37,38]. The assumption that the material fines are responsible for the increase in stiffness was tested by comparing an open graded material (OG, 10 – 100 mm) with a dense graded one (DG, 0 – 100 mm).

Figure 1 shows the laboratory set up of the confined specimen of recycled concrete aggregate. Figure 2 summarizes the results.

RCA exhibits higher tri-axial strength than natural aggregate and an open grading performs better than a dense grading. The latter observation did not support the assumption that the stiffness development was due to the binding of the RCA fines. However, field measurements of E-modulus, performed 1,5 year after the material was placed, show that – given the time to develop - the dense graded material exhibits the highest stiffness [38].

Two special features of the material in the test have to be mentioned: the material had exceptionally high mechanical properties as measured by the LA test (25–27), and the RCA came from newly cast concrete elements, implying that the level of un-hydrated cement particles was high. Nevertheless, the over-all conclusion from this work is that the performance of RCA in a road structure compensates for the apparent lack of mechanical properties on the particle level. This means that the LA-number in itself need not restrict the use of RCA in unbound applications and that more work should be carried out in order to establish the correct relations. In the NPRA-program, the effect of fines on frost heave was also investigated [39].

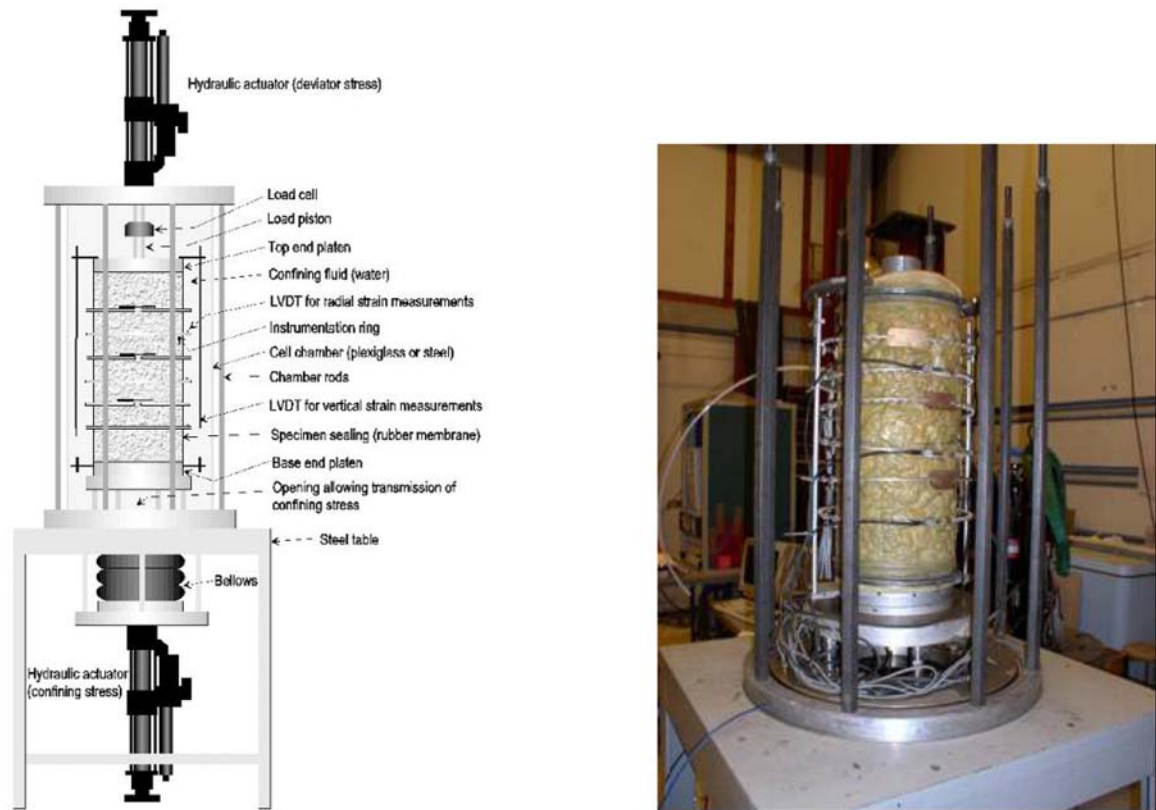

Figure 1. Laboratory set up for the tri-axial test of RCA [38]

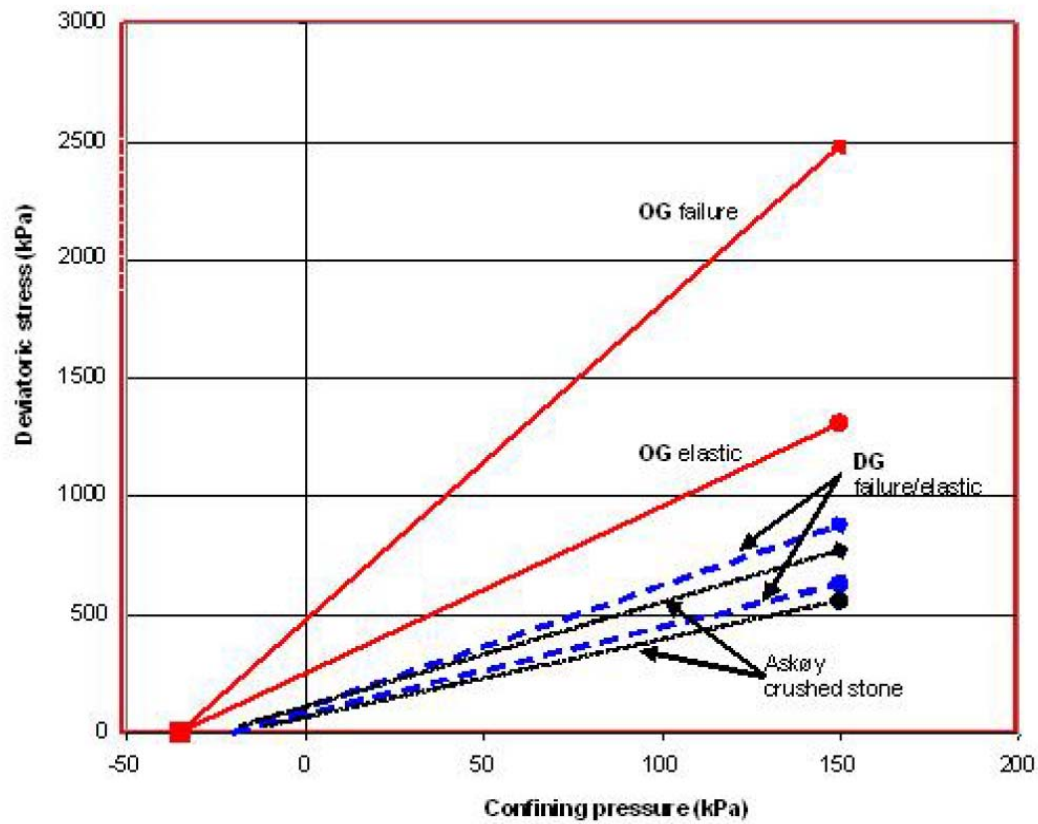

Figure 2. Deviatoric stress as a function of confining pressure for open graded RCA (OG), dense graded RCA (DG), compared to natural aggregate from Askøy (blue dotted line) [38]

Freezing and thawing resistance

Resistance to freezing and thawing is an important property for outdoor applications of RCA. As in the case of mechanical properties, the test methods for frost resistance are not suitable for RCA. A pre-drying procedure and testing under submerged instead of saturated conditions, not crucial for the test procedure itself, unnecessarily disqualify RCA. In the NPRA program, the effect of modified sample preparation procedures was tested [40,41], leaving out unnecessary pre-drying and testing in submerged conditions. In addition, the effect of testing with water containing NaCl was investigated. Figure 3 shows the loss of mass for various specimen preparation methods.

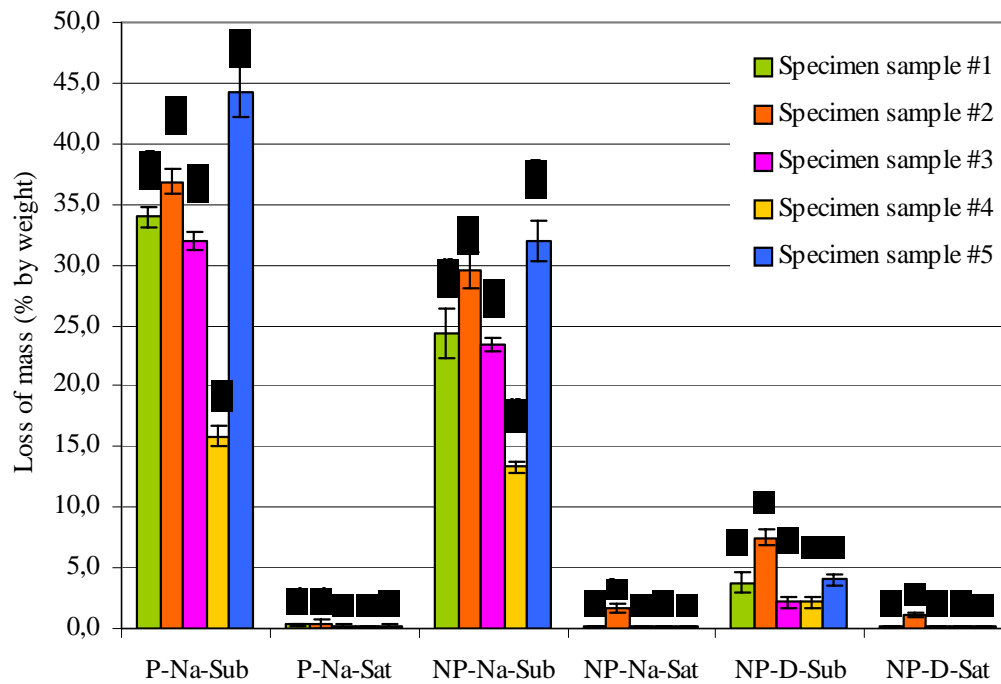

Figure 3. Results of measurement of mass loss [41]. P/NP (pre-dried or not), Na/D (salt containing water or distilled), Sub/Sat (submerged or saturated)

The conclusion of this work was that frost properties of RCA are satisfactory if the specimen preparation method is adjusted. However, applications of RCA in submerged *and* frost exposed conditions are not recommended.

Deterioration from water flow

Unbound applications where the material is exposed to steady water flow (as in trenches or backfills) motivated the investigation of material deterioration under the influence of running water [42, 43]. An accelerated laboratory test was carried out in a specially designed laboratory set-up, as shown in Figure 4. The set-up consisted of two series of four columns each, filled with RCA 10 – 20 mm and exposed to running water. One series contained neutral water (pH=8), the other acid water (pH=4). One column from each series was taken out of the set-up after 237, 419 and 600 days, respectively. Physical and mechanical properties were tested and compared. Figure 5 shows the change in the content of acid soluble material.

The properties of the RCA mainly changed in two ways: the total mass and the particle size distribution. A material loss of about 10 % was observed. The change in particle size distribution suggests a deterioration mechanism for the RCA consisting of an initial period of particle break-up followed by a period with equilibrium conditions leading to a stable particle size distribution. The effect was more pronounced in an acidic environment. After the exposure to water flow the RCA still satisfies the requirements for mechanical strength, particle density and water absorption set in the Norwegian Guidelines for Road Construction for use as sub-base material.

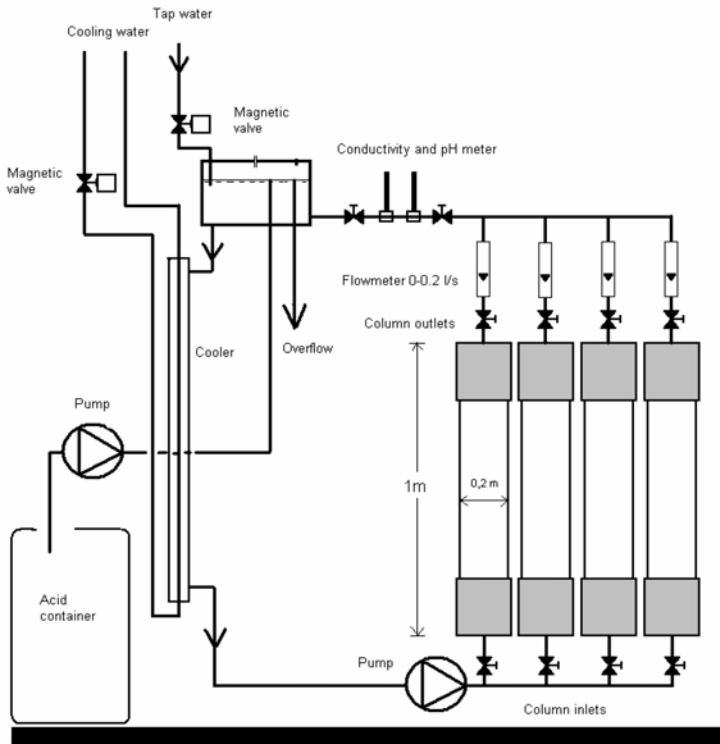

Figure 4. Laboratory water flow test consisting of 2 lines with 4 columns each, with neutral and acid water with pH=8 and 4, respectively [43]

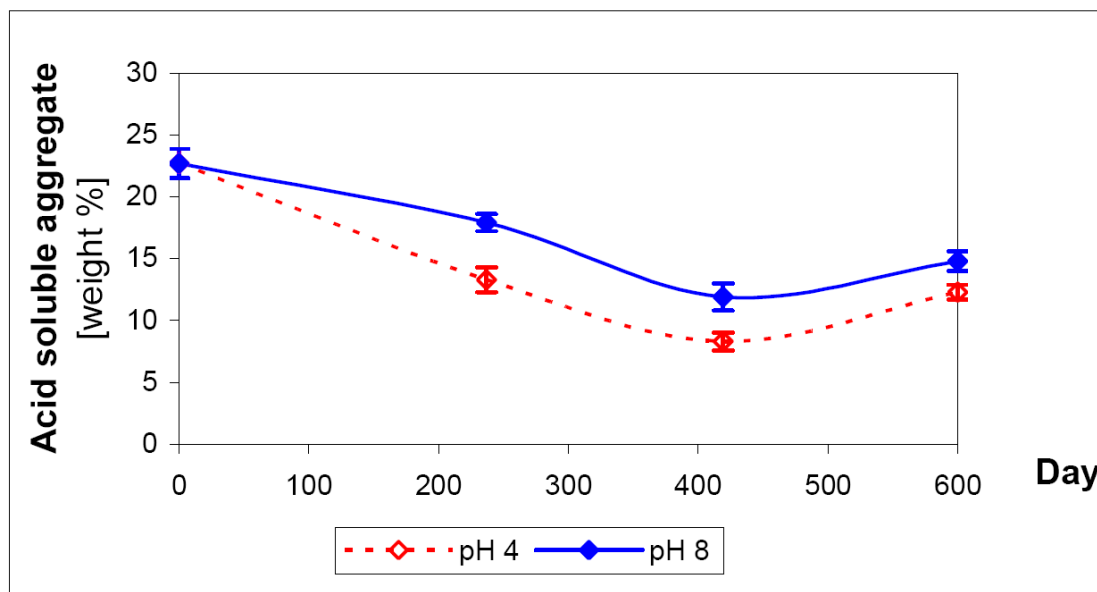

Figure 5. Changes in content of acid soluble material under steady water flow [43]

Environmental impact

Environmental impact was a very important issue in the Norwegian Roads Recycling R&D Program. Extensive work was carried out regarding the factors influencing leaching of pollutants. This included laboratory leaching test, modeling and, finally, full scale tests. An established procedure was applied on all the investigated recycled materials [44,45,46] and an instrumented testing site for investigating environmental properties of recycled materials was developed [47]. The result of this extensive work was the formulation of limiting acceptance values for the content of pollutants in recycled materials in the most usual cases in road construction [45,48], see Table 3. The formulation of content limits was performed by transferring the maximum calculated *pore water concentrations* (leachability), obtained by using Norwegian guidelines, into maximum acceptable *content of pollutants* in the material composition. In cases where this approach gave non-conservative results, other criteria were used (last column in the table).

Table 3. Limiting values for content of pollutants in cement based waste materials [48]

Parameter	Documented max content	Soil criteria sensitive land use	¹ Scenario specific acceptance criteria (Step II)	² Inverse calculation Criteria for ground /surface water maintained	Chosen acceptance limit	Comment - detrimental criterion for choice of acceptance limit
RECYCLED CONCRETE AGGREGATE [mg/kg]						
As	6,4	2	³ 20	33	³ 20	Step II
Pb	185	60	1400	873	200	max documented content
Cd	1,5	3	14	2,2	3	Step I - soil criteria
Cu	224	100	⁷ < 10.000	546	250	max documented content
Cr tot	120	25	⁷ < 10.000	⁴ 55	⁵ 110	inverse calc. - surface water
Hg	0,07	1	230	0,7	1	Step I - soil criteria
Ni	107	50	1700	182	110	max documented content
Zn	553	100	⁷ < 10.000	1455	600	max doc. content
PAH total	< 2	2	116	1182	2	Step I - soil criteria
PCB	< 0,01	0,01	0,72	2,1	⁶ 0,01	Step I - soil criteria

1. Toxicity to humans or ecological impacts on flora and fauna
2. Calculated in relation to the criterion for ground and surface water quality
3. Based on recommendations from Norwegian Geological Survey (NGU 1999) concerning As in inorganic substances
4. Assumed to be Chrome VI
5. Acceptance limit for total Cr assuming max 50% Cr VI
6. A reasonable acceptance limit would have been 0,1, but 0,01 is chosen due to policy for extinguishing PCB from the environment
7. No unacceptable exposure is expected for concentrations < 10.000 mg/kg

Bound applications – RCA as aggregate in new concrete

Although use in structural concrete is not the main interest of NPRA due to high quality requirements for concrete in outdoor use, the NPRA-program decided to continue earlier testing of bound applications and develop it towards durability related properties. Laboratory mixes with an increasing percentage of RCA in the coarse aggregate range were performed and tested [49]. The results of three types of tests are shown here. Figure 6 shows the development of drying shrinkage as a function of the maturity and a function of the percentage of RCA in the coarse aggregate, Figure 7 shows the results of the freeze and thaw test, while Figure 8 shows the development of compressive strength for varying percentages of RCA in the coarse aggregate.

The over-all conclusion from this work is that recycled concrete aggregate is a good replacement for natural aggregate and, with up to a share of 40 % of the coarse fraction, almost no effect can be observed on either strength or durability properties.

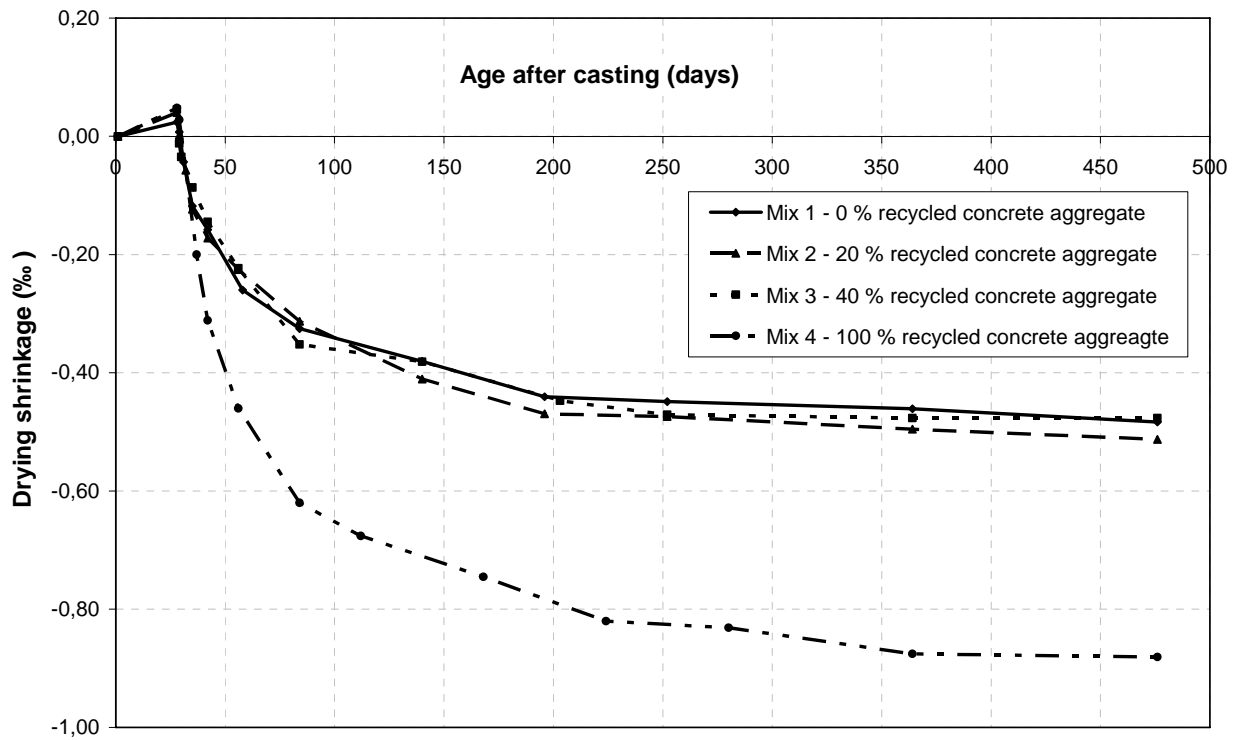

Figure 6. Drying shrinkage as a function of maturity and percentage RCA in the mix [49].

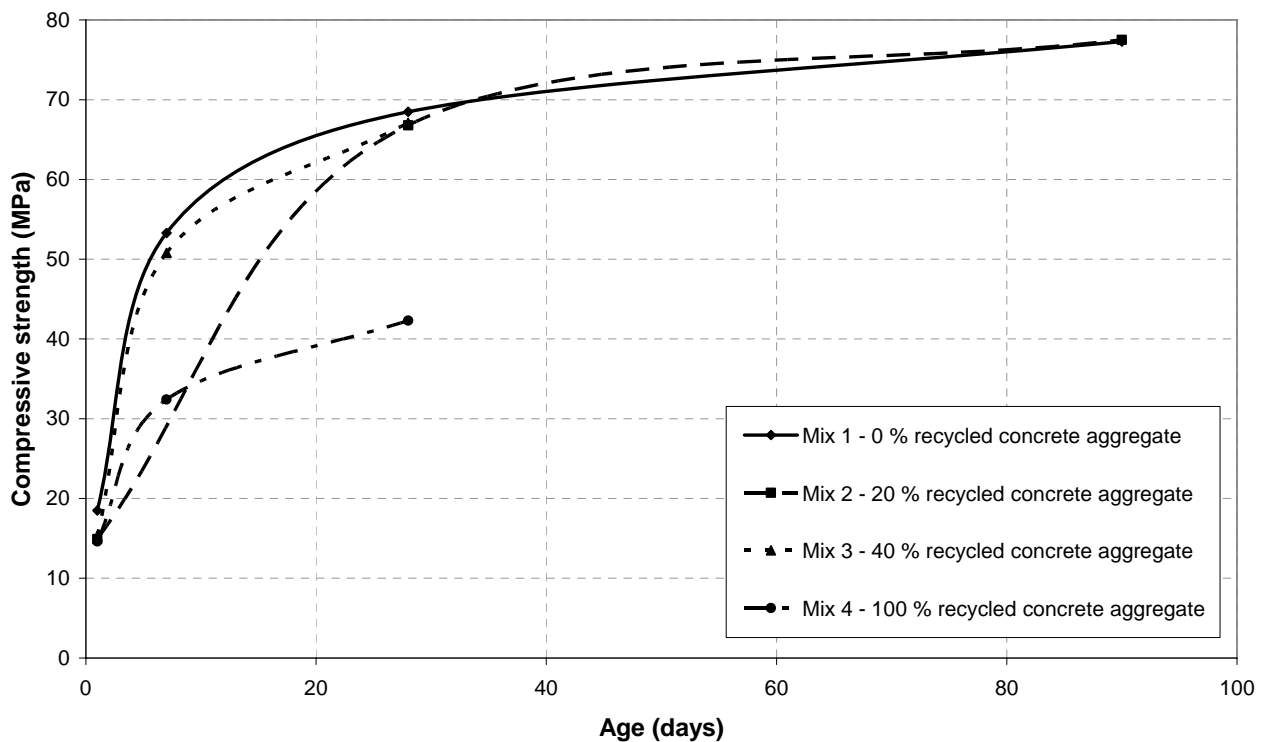

Figure 7. Development of compressive strength for various mixes of concrete added RCA [49]

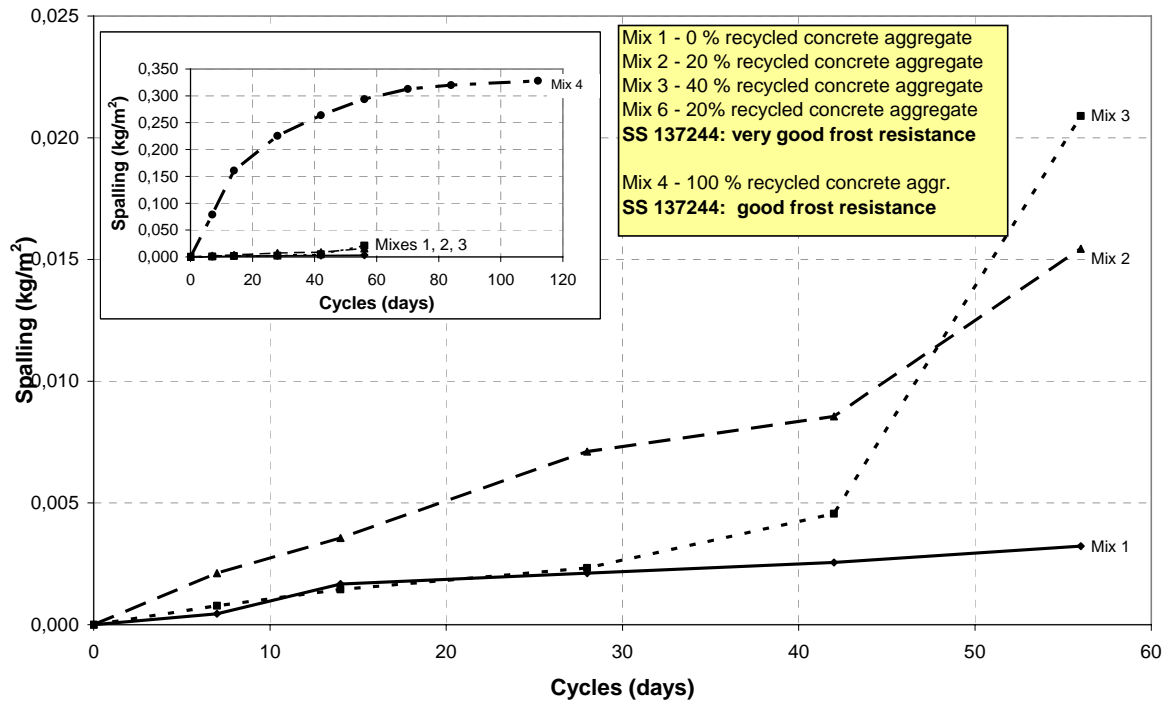

Figure 8. Frost spalling of concrete med varying percentage of RCA [49]

A full scale structure was cast with coarse aggregate consisting of RCA only [50]. The structure is a retaining wall with design strength of 45 MPa, and a w/c ratio of 0,4. The casting included problems with logistics, workability of fresh concrete and clogging of the concrete pump. These practical problems were partly due to the fact that this was an irregular casting job, requiring special arrangements and modifications. The result, however, was a success; Figure 9 shows the wall surface after removing the formworks. The 100%-concrete mix was also tested in the laboratory, and the results included in the over all judgement of concrete with RCA, Fig 6 – Fig 8 [49].



Figure 9. Retaining wall with 100% RCA in the coarse aggregate

DISSEMINATION OF RESULTS

The Norwegian Roads Recycling R&D Program aimed at openness and free dissemination of results. At the beginning of each program year, a seminar was organized where the program's results were presented and topics of current interest for the Norwegian construction and recycling industry discussed. News from the program was also published in newsletters, both printed and distributed by e-mail. The program web site was actively used:

www.gjenbruksprosjektet.net.

RECYCLING IN NORWEGIAN CONDITIONS

The situation on the market does not reflect the level of documentation and technical specifications for recycled concrete aggregate. The production plant for RCA that existed at the start of the program is still the only production plant in the Oslo area. The use of recycled materials in road construction requires larger quantities at a time, meaning that individual demolition jobs usually cannot satisfy the needs.

The waste seems to find other, shorter paths to reuse. Shorter paths imply cheaper transport, which seems to be the main factor and main criterion for the choice of reusing method. However, it also implies poorer knowledge and documentation of the material, which in the next round limits the possibilities for high quality application. The quality certifications scheme [30], aimed at developing RCA as a product, was unfortunately not adapted by any producers. It was prematurely withdrawn in anticipation of the CEN product standards and additional clauses to include RCA.

The management of C&D waste in Norway is carried out mainly from the aspect of preventing secondary pollution. Materials of good quality can end up in low quality applications, simply because of the fact that no other requirement is put on the type (or level) of reuse of the C&D waste. During 2007 criteria for waste management will be introduced in all municipalities in Norway. However, also in this case, secondary pollution is the main criterion.

CONCLUSIONS

At the initiation of the Norwegian Roads Recycling R&D Program, recycling was an attractive issue for the Norwegian building industry. Expectations towards the Norwegian Public Roads Administration were high and explicit, and lead to the decision to invest in a 4-year R&D program. The experience gained and documents generated are a significant contribution to the current knowledge on recycled materials in road construction.

What the road authorities gained altogether is however less clear. The work put into laboratory and field testing, modeling, full scale testing, documentation of results, developing *products* instead of *materials* has still left the road authorities without the economical advantages that the work pointed out as a possibility. It turned out that environmental politics that motivated the initiation of the program, became one of the reasons for its limited over-all success.

After years of systematic work on recycled materials – laboratory testing, field applications, construction processes etc, it seems as if technical issues are either solved or solvable, and technical problems that require more work can easily be pointed out. Under Norwegian

conditions described here, where there is no real urge for recycling, the political framework for recycling becomes the critical part.

In addition to defining high over-all ambitions and aims, it is important to recognize partial goals and to find ways of supporting the means that are necessary for achieving them. The future of recycling may therefore be dependent on the willingness and ability of the authorities to participate in research and demonstration projects resulting in appropriate legislation and control measures.

ACKNOWLEDGEMENT

The author is indebted to all the participants of the Norwegian Roads Recycling R&D Program for their fine work, good will to share their knowledge and to work together towards an optimistic goal! In addition to the members of the program group: Jan Erik Lien, Geir Berntsen, Sigmund Dørum, Roald Aabøe, Dag Atle Tangen and the leader of the program council, Elisabeth Schjølberg, all from NPRA, the authors contributing to the reports and papers (see reference list) are also highly acknowledged. The program had a stable budget and good support from the leadership in NPRA. The program partners were also supportive and determined on making progress towards more environmentally friendly waste management and road construction.

REFERENCES

- ¹ www.gjenbruksprosjektet.net, Norwegian Public Roads Administration, 2002
- ² Ministry of the Environment, 2000-2001. Summary in English: Report No. 24 to the Storting (2000-2001). The Government's Environmental Policy and the State of the Environment. <http://www.dep.no/md/engelsk/publ/stmeld/022001-040011/>
- ³ Ministry of the Environment, Report No. 21 to the Storting (2004-2005). The Government's Environmental Policy and the State of the Environment.
- ⁴ Ministry of the Environment, Report No. 26 to the Storting (2006-2007). The Government's Environmental Policy and the State of the Environment.
- ⁵ The Federation of Norwegian Construction Industries, 2001. Nasjonal handlingsplan for bygg- og anleggsavfall (National Action Plan for Construction Waste, in Norwegian). <http://www.grip.no/Okobygg/nasjonalhandlingsplan.htm>
- ⁶ The Federation of Norwegian Construction Industries, 2007-2012. Nasjonal handlingsplan for bygg- og anleggsavfall (National Action Plan for Construction Waste, in Norwegian), http://coreweb.nhosp.no/byggemiljo.no/html/files/NHP_-_Rapport_300407_2.pdf.
- ⁷ Norwegian Pollution Control Authority: TA-1853, Bygg- og anleggsavfall: Disponering av rene naturlige masser og gjenvunnet materiale
- ⁸ Statistics Norway, 2004, Waste from construction works (in Norwegian): <http://www.ssb.no/emner/01/05/avfbyggan/>
- ⁹ Institute of Asphalt Technology, 2001, 2002, 2003, 2004, 2005. Annual reports from the Control System for Reclaimed Asphalt (in Norwegian). <http://www.asfaltteknisk.no/kfa>
- ¹⁰ Håøya, A-O et al.: "Reuse of vehicle tires in road construction – Technical and mechanical properties", Report nr 5, Norwegian Roads Recycling R&D Program, Techn.report nr 2357 (in Norwegian)
- ¹¹ Ruud, O. et al.: "Hot mix recycling in asphalt plants", Report nr 3, Norwegian Roads Recycling R&D Program, Techn.report nr 2350 (in Norwegian)
- ¹² Ruud, O.: "Control and documentation of reclaimed asphalt", Report nr 4, Norwegian Roads Recycling R&D Program, Techn.report nr 2351 (in Norwegian)
- ¹³ Stenshagen, J. and Moen, Ø.: "Material properties for cold mixed reclaimed asphalt", Report nr 7 report 7, Norwegian Roads Recycling R&D Program, Techn.report nr 2420 (in Norwegian)

- ¹⁴ Evensen, R.: "Material stream for reclaimed asphalt", Report nr 9, Norwegian Roads Recycling R&D Program, Techn.report nr 2410 (in Norwegian)
- ¹⁵ Aurstad, J.: "Experience with applications with cold mixed reclaimed asphalt", Report nr 6, Norwegian Roads Recycling R&D Program, Tech.report 2408 (In Norwegian)
- ¹⁶ Bragstad, R.: "Field tests with unbound asphalt aggregate – Final field tests at Fornebu", Report nr 8, Norwegian Roads Recycling R&D Program, Tech.report 2421 (in Norwegian)
- ¹⁷ Jørgensen, T. et al.: "Environmental impact of recycled materials – Reclaimed asphalt", Report nr 14b, Norwegian Roads Recycling R&D Program, Tech.report 2434 (in Norwegian)
- ¹⁸ Håøya, A.-O. et al.: "Environmental impact of recycled materials – Shredded tires", Report 14c, Norwegian Roads Recycling R&D Program, Techn.report 2435 (in Norwegian)
- ¹⁹ CEN Workshop agreement, Post-consumer Tyre Materials and Applications, CWA 14243:2002E.
- ²⁰ Norwegian Building Research Institute, 2000. RESIBA, www.byggforsk.no/prosjekter/resiba
- ²¹ Engelsen et al.: "Leaching characteristic of unbound recycled aggregates: Preliminary study and ongoing research", WASCON 2003, Fifth International Conference on the Environmental and Technical Implications of Construction with Alternative Materials, 4-6 June 200, San Sebastian, Spain.
- ²² Mehus, J., Skaare, L., Myhre, Ø. 2002. Unbound use of recycled concrete aggregate in utility trenches. RESIBA report 06/2002. Oslo: Norwegian Building Research Institute. (in Norwegian)
- ²³ Mehus, J. et al.: "Recycled concrete aggregate a viable alternative for the Norwegian building and construction industry", WASCON 2003, 5th International Conference on the Environmental and Technical Implications of Construction with Alternative Materials, 4-6 June 200, San Sebastian, Spain.
- ²⁴ Lahus, O., Lillestøl, B., Hauck, C. 2002. Use of recycled concrete aggregate as aggregate in normal concrete in Norway. Sustainable Building 2002.
- ²⁵ Myhre, Ø., Skaare, L., Mehus, J. 2002. Unbound use of recycled concrete aggregates in roads and parking lots. RESIBA report 05/2002, NBI Report no. 330. Oslo: Norwegian Building Research Institute. (in Norwegian)
- ²⁶ Mehus, J., Skaare, L., Myhre, Ø. 2002. Unbound use of recycled concrete aggregate in utility trenches. RESIBA report 06/2002. Oslo: Norwegian Building Research Institute. (in Norwegian)
- ²⁷ Norwegian Concrete Association, 1999. Publication no. 26. Recycled material from concrete and bricks for use in production of concrete.
- ²⁸ Skytterholm, O. & Mehus, J. 2002. Guidelines for the use of recycled concrete aggregate. RESIBA-project report. (in Norwegian)
- ²⁹ Karlsen, J., Petkovic, G. & Lahus, O. 2002. A Norwegian certification scheme for recycled concrete aggregate. Sustainable Building 2002.
- ³⁰ Kontrollrådet, Tekniske bestemmelser Klasse V, "Technical requirements for recycled concrete aggregate" (in Norwegian), www.kontrollbetong.no
- ³¹ Norwegian Public Roads Administration 2005. Manual 018 Road Construction. Oslo: NPRA. (in Norwegian)
- ³² Myren, S. and Mehus, J.: "Testing the quality certifications scheme for recycled concrete aggregate", Report nr 13, Norwegian Roads Recycling R&D Program, Tech.report 2431 (in Norwegian)
- ³³ Aurstad, J.: "Recycling of concrete and masonry. Testing of mechanical properties - Experiences", Report nr 1, Norwegian Roads Recycling R&D Program, Tech.report 2309 (in Norwegian)
- ³⁴ Aksnes, J. and Tangen D.A.: "The recycled road E6 Melhus", Report nr 12, Norwegian Roads Recycling R&D Program, Tech.report 2422 (in Norwegian)
- ³⁵ Rangen, D. et al.: "Recycled road E6 Klemetsrud – Assurtjern", Report nr 18, Norwegian Roads Recycling R&D Program, Tech.report 2441 (in Norwegian)
- ³⁶ Aurstad, J.: "Reuse of concrete in road construction – Mechanical properties and test methods", Report nr 11, Norwegian Roads Recycling R&D Program, Tech.report 2422 (in Norwegian)
- ³⁷ Aurstad, J. et al.: "Evaluation of unbound crushed concrete as road building material – Mechanical properties vs field performance", The 26th International Baltic Road Conference, 28.-30. August 2006
- ³⁸ Aurstad, J. et al.: "Unbound crushed concrete in high volume roads – A field and laboratory study", Research and Practical Application Using Waste and Secondary Materials in Pavement Engineering, JMU Liverpool, 22. - 23. February 2006.

- ³⁹ Aurstad, J.: “Fines in recycled concrete aggregate”, Report nr 15, Norwegian Roads Recycling R&D Program, Tech.report 2437 (in Norwegian)
- ⁴⁰ Myren, S. and Mehus, J.: “Frost resistance of RCA”, Report nr 10, Norwegian Roads Recycling R&D Program, Tech.report 2411 (in Norwegian)
- ⁴¹ Petkovic, G. et al.: “Recycled concrete aggregate – Durability aspects”, Durability and Maintenance of Concrete Structures, Dubrovnik, Croatia, October 2004.
- ⁴² Engelsen, C.J. et al.: ”Chemical deterioration of recycled concrete aggregate – Test with accelerated water drainage” Report nr 16, Norwegian Roads Recycling R&D Program, Tech.report 2438 (in Norwegian)
- ⁴³ Plesser, T. et al.: “Deterioration of RCA under the influence of steady water drainage”, WASCON, Sixth International Conference on the Environmental and Technical Implications of Construction with Alternative Materials, Beograd, Serbia and Montenegro, 31. May - 2. June 2006.
- ⁴⁴ Petkovic, G. et al: “Environmental impact from the use of recycled materials in road construction – Method for decision-making in Norway”, Resources, Conservation & Recycling, Volume 42, Issue 3, October 2004, pp. 249-264
- ⁴⁵ Petkovic. G. et al.: “Environmental impact of recycled materials”, Report nr 14, Norwegian Roads Recycling R&D Program, Tech.report 2432 (in Norwegian)
- ⁴⁶ Engelsen, J. et al.: “Environmental impact of recycled materials – Cement based materials”, Report nr 14a, Norwegian Roads Recycling R&D Program, Tech.report 2433 (in Norwegian)
- ⁴⁷ Engelsen, C.J.: “Constituent release predictions for recycled aggregates at field site in Norway”, WASCON 2006, 6th International Conference on the Environmental and Technical Implications of Construction with Alternative Materials, Beograd, Serbia and Montenegro, June 2006
- ⁴⁸ Petkovic, G. et al.: “Acceptance limits for the content of pollutants in recycled materials in road construction”, TRA-conference, Gothenburg 2006, www.traconference.com
- ⁴⁹ Myren, S. and Mehus, J.: “Structural concrete with recycled concrete aggregate”, Report nr 17, Norwegian Roads Recycling R&D Program, Tech.report 2439 (in Norwegian)
- ⁵⁰ Tangen, D.A.: “Retaining wall at Taraldrud – Practical experience with use of RCA as concrete aggregate”, Report nr 17a, Norwegian Roads Recycling R&D Program, Tech.report 2440 (in Norwegian)